



Indian School Al Wadi Al Kabir
Assessment 1
Engineering Graphics (Code: 046)
SET 1

Class : XII
Date : 22/09/2022

Time: 3 Hours
Max. Marks : 70

General Instructions:

- i. Attempt all the questions.
- ii. Use both sides of the drawing sheet, if necessary.
- iii. All dimensions in millimeters.
- iv. Missing and mismatching dimensions, if any, may be suitably assumed.
- v. Follow the SP: 46-2003 revised codes (with first angle method of projection).
- vi. Number your answers according to questions.

5 x 1 = 5

Q.I.i) Which of the following bearing will be having a “U” shaped cast iron body?

- | | |
|-------------------|--------------------------|
| a) Bushed bearing | b) Footstep bearing |
| c) Open bearing | d) Plummer block bearing |

ii) Which one of the following is not a temporary fastener?

- | | |
|----------|---------|
| a) Nut | b) Bolt |
| c) Rivet | d) Stud |

iii) What is the angle difference between true length and isometric length?

- | | |
|--------------|---------------|
| a) 30-degree | b) 120-degree |
| c) 60-degree | d) 15-degree |

iv) How many cotters is used in a sleeve and cotter joint?

- | | |
|------|------|
| a) 1 | b) 4 |
| c) 2 | d) 3 |

v) Which machine part is a headless bolt-----

- a) Nut
- b) Stud
- c) Rivet
- d) Screw

Q.2. (a) Construct an isometric scale of length 80 mm. **4**

(b) Draw the isometric projection of an equilateral triangular prism of 50 mm base side and 75 mm axis resting on its base in H.P. with one of its base edge parallel to V.P. in front. **8**

(c) Draw an Isometric Projection of an equilateral triangular pyramid resting vertically and centrally with one base edge, at the back, parallel to V.P. on the top face of a hexagonal prism having two of its rectangular faces parallel to V.P. Side of the triangle = 34 mm, height of pyramid = 50 mm, side of the hexogen = 30 mm and height of the prism = 60 mm. **12**

Q.3. (a) Draw to scale 1:1, the standard profile of the Metric thread (external) with the pitch=50mm. Give standard dimensions. **8**

OR

Draw to scale 1:1, the front view and side view of a hexagonal headed bolt with diameter 30 mm, keeping its axis parallel to both VP and HP. The length of the bolt is 120 mm. Give standard dimensions.

(b) Sketch free hand the front view and side view of a collar stud of diameter = 20 mm. keeping its axis parallel to HP and VP. Give standard dimensions. **5**

OR

Sketch free hand the front view and top view of a Pan head rivet of diameter 20 mm, keeping its axis vertical. Give standard dimensions.

Q.4. The figure shows the details of the parts of an Open bearing. Assemble these parts correctly and then draw the following views to scale 1:1.

- (a) Front view right half in section,
- (b) Top view
- (c) Print title, scale used and give all dimensions.

28

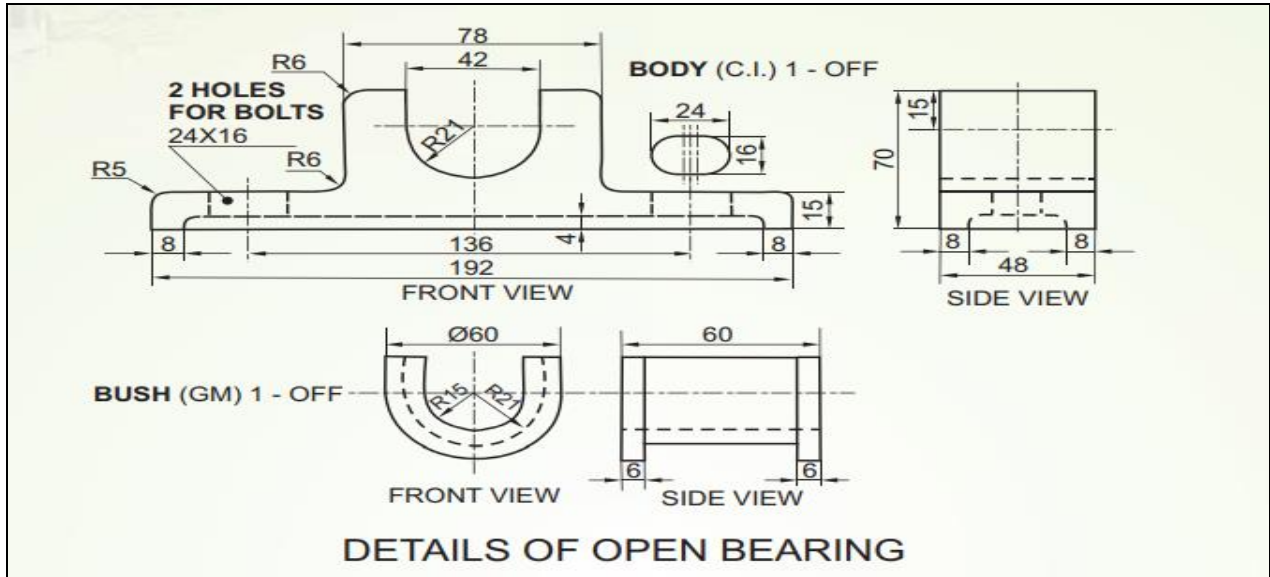

OR

The figure given below shows the assembly of a Sleeve and Cotter Joint. Disassemble the following parts and draw the following views to a full-size scale.

- (a) Front view of the sleeve and side view viewing from left.
- (b) Front view of Rod A and Rod B and side view viewing from left.
- (c) Front view of cotter in vertical position and the top view.

Print titles and scale used. Draw the projection of symbol. Give 8 important dimensions

